

Finishing Process

## MRC-200\_VIB Grinding Machine



It rectifies the body of cork stoppers for the required diameter (regulation of the ovality of the surface).



### Source

Power Supply  
415/240V (3Ph+N+T) 50 Hz



### Power

Installed Power 10.0 kW



### Compressed Air

NA



### Noise

< 70 dB



### Cadence

Nominal cadence  
15 000 to 20 000 corks/hour  
(24x38 mm)

## General Features

- ✓ Possibility of rectifying corks with different dimensions;
- ✓ Semi-automatic system for stones cleaning;
- ✓ Monitoring of the effort made in the grinding operation;
- ✓ Wide range of feeding systems to be chosen by the customer.

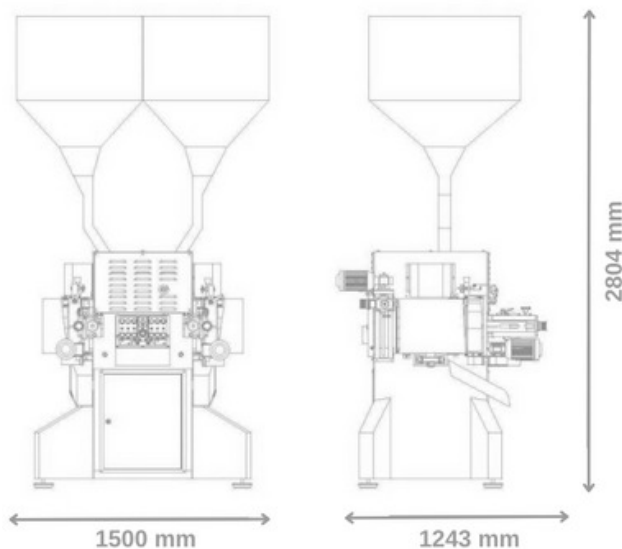

### Dimensions

H 2804 mm x D 1243 mm x W 1500 mm

### Weight

750 kg



[www.azevedosindustria.com](http://www.azevedosindustria.com)

Lourosa, Portugal

+351 22 747 15 70 (Call cost for national fixed network) ▪ [geral@azevedosindustria.com](mailto:geral@azevedosindustria.com)

